



Town of Merrimack, New Hampshire

6 Baboosic Lake Rd · Merrimack, NH 03054 · www.merrimacknh.gov

January 11, 2024

REQUEST FOR BID CAST IRON MANHOLE FRAMES AND COVERS HINGED BALL AND SOCKET SYSTEM

Sealed bids will be received by the Town of Merrimack until 2:00 PM on Friday, January 26, 2024 to supply forty eight (48) 30" diameter and two (2) 36" diameter cast iron manhole frames and covers to the Waste Water Treatment Facility in accordance with the enclosed detailed bid specifications and following conditions:

The bid shall be submitted on the Bid Form furnished herewith and shall exclude state and federal taxes not applicable to municipalities. The bid price shall be quoted F.O.B. Town of Merrimack, Waste Water Treatment Facility, 36 Mast Road, Merrimack, NH.

The Town reserves the right to reject any or all bids, to waive irregularities in the bids, and to accept the bid which best serves the interest of the Town.

Bids must be sealed, marked "Bid on Cast Iron Manhole Frames & Covers", and mailed to the Town of Merrimack Finance Department, 6 Baboosic Lake Rd, Merrimack, NH 03054 by the date and time specified above.

It is the bidder's responsibility to confirm the bid is received by the Finance Department by the date and time specified.

The Town of Merrimack's Purchasing Policy is available on the Town's website:
http://www.merrimacknh.gov/town/departments/finance/bid_opportunities;
a copy may be obtained by contacting the Purchasing Agent.

For additional information contact Kelly Valluzzi, Purchasing Agent, at
kvalluzzi@merrimacknh.gov or (603) 424-7075.



Town of Merrimack, New Hampshire

6 Baboosic Lake Rd · Merrimack, NH 03054 · www.merrimacknh.gov

BID SPECIFICATIONS CAST IRON MANHOLE FRAMES AND COVERS HINGED BALL AND SOCKET SYSTEM

PART 1 GENERAL

1.1 SECTION INCLUDES

- A. Cast iron manhole frames and covers. **Quantity desired is 48 manhole frames and covers.** The number purchased will be dependent on bid price and available budget.

1.2 RELATED SECTIONS

- A. Division 01 Section "General Requirements"
- B. Division 01 Section "Special Procedures"
- C. Division 31 Section "Backfilling"
- D. Division 33 Section "Sanitary Sewerage Utilities"

1.3 REFERENCES

- A. ASTM International (ASTM):
 - 1. ASTM A48 - Standard Specification for Gray Iron Castings.
 - 2. ASTM A536 - Standard Specification for Ductile Iron Castings.
- B. American Association of State Highway and Transportation Officials (AASHTO):
 - 1. M 306-10 – Standard Specification for Drainage, Sewer, Utility, and Related Castings.

1.4 SUBMITTALS

- A. Submit under provisions of Section 01 30 00 - Administrative Requirements.
- B. Shop Drawings: Manufacturer's data sheets on each product to be used, including:
 - 1. Provide manhole covers, materials, component construction, features, configuration, and dimensions.
- C. Must submit American Iron and Steel Certification for any supplied covers.

1.5 QUALITY ASSURANCE

- A. Manufacturer Qualifications: Minimum 5 year experience manufacturing similar products.
- B. Installer Qualifications: Minimum 2 year experience installing similar products.



1.6 DELIVERY, STORAGE, AND HANDLING

- A. Deliver and store products in manufacturer's unopened packaging bearing the brand name and manufacturer's identification until ready for installation.
- B. Handling: Handle materials to avoid damage.

1.7 Sequencing

- A. Ensure that products of this section are supplied to affected trades in time to prevent interruption of construction progress.

1.8 WARRANTY

- A. Warranty: Manufacturer's standard limited warranty.
 - 1. Warranty Period: One year from date of Invoice.

PART 2 PRODUCTS

2.1 MANUFACTURERS

- A. Acceptable Manufacturer: Neenah Foundry Co., which is located at: 2121 Brooks Ave. P. O. Box 729; Neenah, WI 54957; Toll Free Tel: 800-558-5075; Tel: 920-725-7000; Fax: 920-729-3661; Email:[request info \(construction.sales@neenahenterprises.com\)](mailto:request info (construction.sales@neenahenterprises.com)); Web:www.nfco.com
- B. Substitutions: Not permitted.
- C. Requests for substitutions will be considered in accordance with provisions of Section 01 60 00- Product Requirements.

2.2 CAST IRON MANHOLE FRAMES AND COVERS

- A. Heavy Duty Manhole Frames and Covers:
 - 1. Material: Cast Gray Iron (ASTM A48 Class 35-B) for heavy-duty use.
 - 2. Catalog Number: R-1743-LM
 - 3. Clear Open Area Diameter: 30 inches.
 - 4. Frame Height: 6 inches.
 - 5. Cover: Type "C" Solid Lid
 - 6. Anchor Bolt Holes: (4) 1 inch diameter holes equally spaced on 36-7/8 inch diameter bolt circle.
 - 7. Finish: All castings shall be manufactured true to pattern; component parts shall fit together in a satisfactory manner. They shall be of uniform quality; free from blowholes, porosity, hard spots, shrinkage distortion or other defects. They shall be well cleaned by blasting.
 - 8. **Special Conditions:**
 - a. Gasket: Oil-Resistant, Nitrile, Secured to Cover.
 - b. Hinge: Ball and Socket Hinge System.
 - c. Safety Device: Hold Open Safety Arm.
 - d. Surface: Permagrip Texture.
 - e. Opening Pick Hole: Pickmattock Handhole
 - f. Loading Requirements: H-20.

PART 3 EXECUTION

3.1 EXAMINATION

- A. Examine substrates for compliance with requirements for installation. Proceed with installation only after unsatisfactory conditions have been corrected.
- B. Do not begin installation until substrates have been properly prepared and necessary building services are installed.
- C. If substrate preparation is the responsibility of another installer, notify Architect/Engineer of unsatisfactory preparation before proceeding.

3.2 PREPARATION

- A. Clean and prepare surfaces using the methods recommended by the manufacturer for achieving the best results for the substrate under the project conditions.

3.3 INSTALLATION

- A. Install manhole frame and cover in accordance with local standards and approved submittals.
 - 1. Surface of manhole frame and cover to be flush with surrounding pavement. Variation from flush not to exceed plus or minus 1/8 inch (3 mm).

3.4 PROTECTION

- A. Protect installed products until completion of project.
- B. Touch-up, repair or replace damaged products before Substantial Completion.

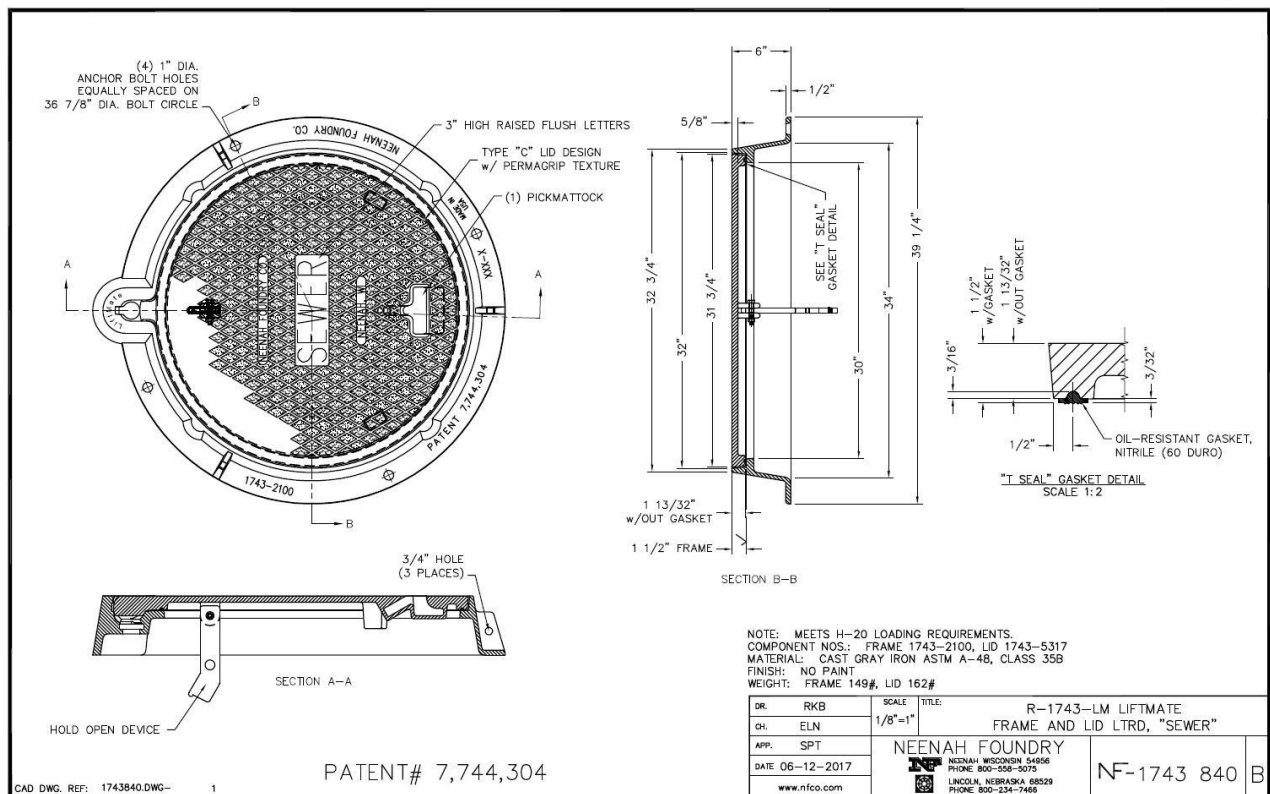

END OF SECTION
BID SPECIFICATIONS
CAST IRON MANHOLE FRAMES AND COVERS
Hinged, Watertight, Cam Locking System

PART 1 GENERAL

1.1 SECTION INCLUDES

- A. Cast iron manhole frames and covers. **Quantity desired is 2 manhole frames and covers.**
The number purchased will be dependent on bid price and available budget.

1.2 RELATED SECTIONS

- A. Division 01 Section "General Requirements"
- B. Division 01 Section "Special Procedures"
- C. Division 31 Section "Backfilling"
- D. Division 33 Section "Sanitary Sewerage Utilities"

1.3 REFERENCES

- A. ASTM International (ASTM):
 - 1. ASTM A48 - Standard Specification for Gray Iron Castings.
 - 2. ASTM A536 - Standard Specification for Ductile Iron Castings.

1.4 SUBMITTALS

- A. Submit under provisions of Section 01 30 00 - Administrative Requirements.
- B. Shop Drawings: Manufacturer's data sheets on each product to be used, including:
 - 1. Provide manhole covers, materials, component construction, features, configuration, and dimensions.
- C. Must submit American Iron and Steel Certification for any supplied covers.

1.5 QUALITY ASSURANCE

- A. Manufacturer Qualifications: Minimum 5 year experience manufacturing similar products.
- B. Installer Qualifications: Minimum 2 year experience installing similar products.

1.6 DELIVERY, STORAGE, AND HANDLING

- A. Deliver and store products in manufacturer's unopened packaging bearing the brand name and manufacturer's identification until ready for installation.
- B. Substitutions: Not permitted.
- C. Requests for substitutions will be considered in accordance with provisions of Section 01 60 00- Product Requirements.

PART 2 PRODUCTS

2.1 MANUFACTURERS

- A. Acceptable Manufacturer: Neenah Foundry Co., which is located at: 2121 Brooks Ave. P. O. Box 729; Neenah, WI 54957; Toll Free Tel: 800-558-5075; Tel: 920-725-7000; Fax: 920-729-3661; Email:[request info \(construction.sales@neenahenterprises.com\)](mailto:request_info_(construction.sales@neenahenterprises.com)); Web:www.nfco.com
- B. Requests for substitutions will be considered in accordance with provisions of Section 01 60 00- Product Requirements.

2.2 CAST IRON MANHOLE FRAMES AND COVERS

- A. Heavy Duty Manhole Frames and Covers:
 - 1. Material: Ductile Iron (ASTM A48) for heavy-duty use.
 - 2. Catalog Number: Neenah Foundry17 Solid Ductile Iron Hinged Cover and Frame.
 - 3. Clear Open Area Diameter: 36 inches.
 - 4. Frame Height: 6 inches.
 - 5. Cover: Solid Cam Locking Lid
 - 6. Anchor Bolt Holes: (4) 1 inch diameter holes equally spaced on along the 46 inch diameter bolt circle.
 - 7. Finish: All castings shall be manufactured true to pattern; component parts shall fit together in a satisfactory manner. They shall be of uniform quality; free from blowholes, porosity, hard spots, shrinkage distortion or other defects. They shall be well cleaned by blasting.
 - 8. Special Conditions:**
 - a. Gasket: Oil-Resistant, Nitrile, Secured to Cover.
 - b. Hinge: Dual Hinge design with 120 degree hold open with Ergo safety Catch.
 - c. Safety Device: Dual hinge with Ergo Safety Catch.
 - d. Surface: Slip Resistant Texture.
 - e. Opening Pick Hole: M-Pick Multi-Tool
 - f. Loading Requirements: H-20.

PART 3 EXECUTION

3.1 EXAMINATION

- A. Examine substrates for compliance with requirements for installation. Proceed with installation only after unsatisfactory conditions have been corrected.
- B. Do not begin installation until substrates have been properly prepared and necessary building services are installed.
- C. If substrate preparation is the responsibility of another installer, notify Architect/Engineer of unsatisfactory preparation before proceeding.

3.2 PREPARATION

- A. Clean and prepare surfaces using the methods recommended by the manufacturer for achieving the best results for the substrate under the project conditions.

3.3 INSTALLATION

- A. Install manhole frame and cover in accordance with local standards and approved

submittals.

1. Surface of manhole frame and cover to be flush with surrounding pavement. Variation from flush not to exceed plus or minus 1/8 inch (3 mm).

3.4 PROTECTION

- A. Protect installed products until completion of project.
- B. Touch-up, repair or replace damaged products before Substantial Completion.

1739 850- 1 B8

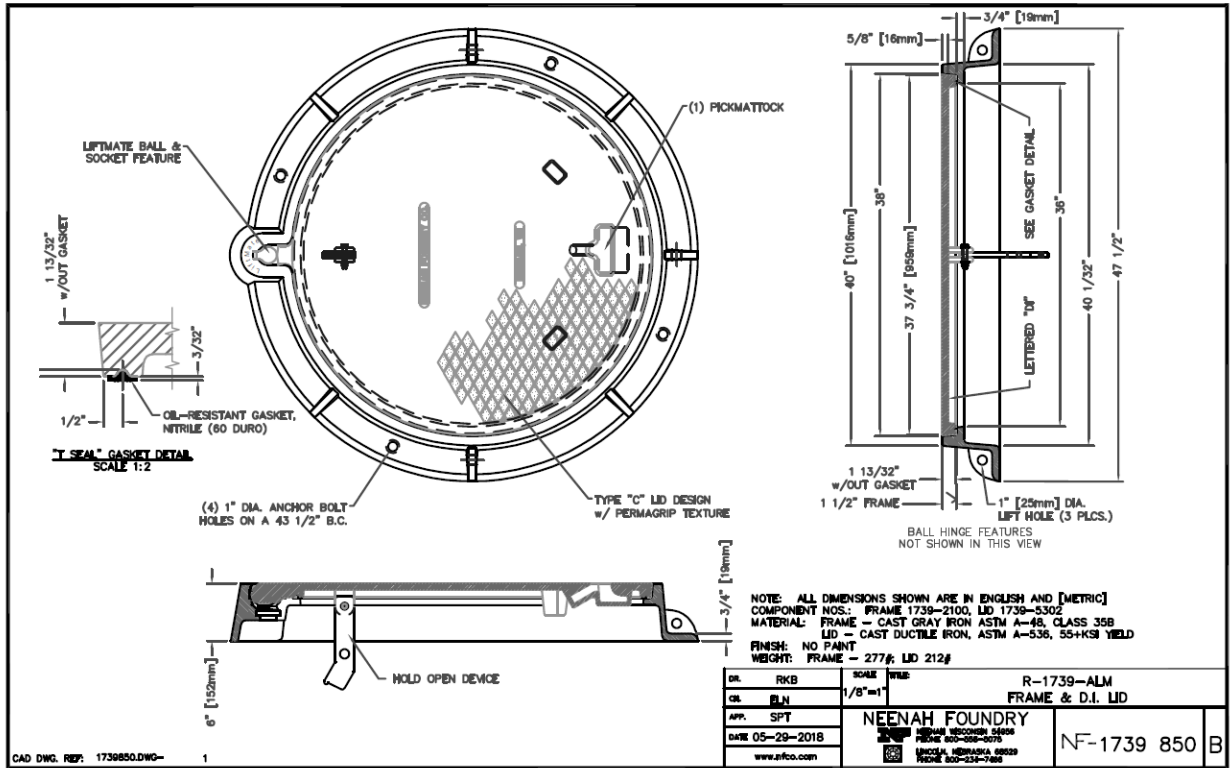



TOWN OF MERRIMACK, NEW HAMPSHIRE

FINANCE DEPARTMENT
6 Baboosic Lake Road
Merrimack, NH 03054

Tel: 603-424-7075
Fax: 603-424-0516

Bid on Cast Iron Manhole Frames and Covers Hinged Ball and Socket System
BID FORM

Due by 2:00 PM on Friday, January 26, 2024

Cast Iron Manhole Covers and Frames (30" diameter)
According to the Town's bid specifications:

\$ _____ ea x 48 = \$ _____

Cast Iron Manhole Covers and Frames (36" diameter)
According to the Town's bid specifications:

\$ _____ ea x 2 = \$ _____

The above bid is provided in accordance with the Town's bid invitation dated January 11, 2024, except as indicated below.

Bidder _____

Street Address _____

City, State, Zip Code _____

Phone No. _____ Fax No. _____

Authorized Signature: _____ Date: _____

Email: _____